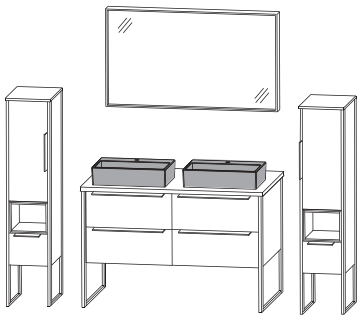
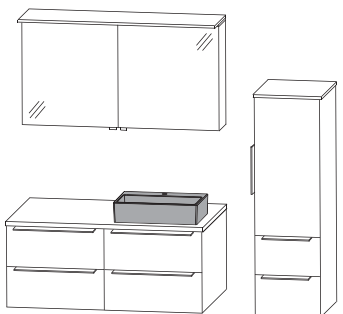
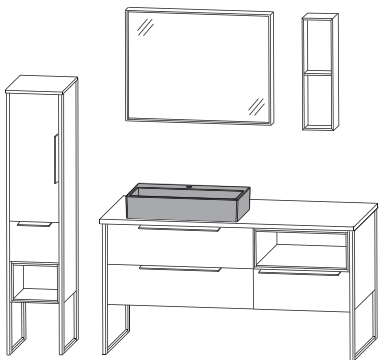

Programm 066 - Planungsbeispiele

ASK-4312-1			
1	Flächenspiegel		F S B 4 5 1 2 0 4
2	Keramik-Aufsatzwaschtisch Squared		W T M 4 8 0 5 4 3
1	Waschtischplatte	A P 5 1 2 4 6 6	
2	Ausschnitt links und rechts	A U S 4 8 0 5 2 8	
2	Waschtischunterschranke	W U A 3 3 6 0 P 3	
2	Seitenaufdopplung	S D H 4 9 7 8 0 1	
2	Mittelschränke	M N S 8 2 3 0 R G	
2	Abdeckplatten	A P N 3 3 3 4 6 6	
4	Seitenaufdopplung	S D H 3 2 1 2 0 1	
Summe			
Aufpreis Hochglanz Korpus		1200 mm breit + 2 x 300 mm breit	
ASK-4312-2			
1	Spiegelschrank		A S P 4 2 1 2 0 1
1	Keramik-Aufsatzwaschtisch Squared		W T M 4 8 0 5 4 3
1	Waschtischplatte	A P 5 0 1 2 6 6	
1	Ausschnitt rechts	A U S 4 8 0 5 2 8	
1	Waschtischunterschranke	W U A 3 3 6 0 P 3	
1	Unterschrank	U T A 3 3 6 0 R G	
1	Mittelschrank	M N A 8 7 4 0 R G	
1	Abdeckplatte	A P N 3 3 4 0 6 6	
Summe			
Aufpreis Hochglanz Korpus		1200 mm breit + 400 mm breit	
ASK-4315-1			
1	Flächenspiegel		F S B 4 5 9 0 0 4
1	Funktionsregal		R G L 1 1 6 0 0 2
1	Keramik-Aufsatzwaschtisch Squared	W T M 4 8 0 6 4 3	
1	Waschtischplatte	A P 5 1 5 4 6 6	
1	Ausschnitt links	A U S 1 1 0 2 2 8	
1	Waschtischunterschrank	W U A 3 3 9 0 P 3	
1	Unterschrank	U T A 3 7 6 A 0 1	
2	Seitenaufdopplung	S D H 4 9 7 8 0 1	
1	Mittelschrank	M N S 8 2 3 1 R G	
1	Abdeckplatte	A P N 3 3 3 4 6 6	
2	Seitenaufdopplung	S D H 3 2 1 2 0 1	
Summe			
Aufpreis Hochglanz Korpus		1500 mm breit + 300 mm breit	

Programm 066 - Maßskizzen

Elektroanschlüsse für Spiegelschränke

WTA S111 1 + WUA 3360 P3 +
2x SDH 4978 01

WTA S112 1 + WUA 3390 P3 +
2x SDH 4978 01

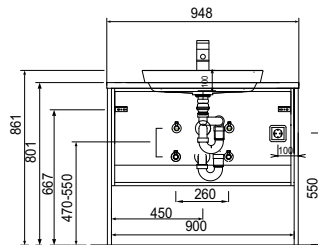
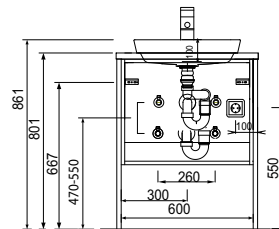
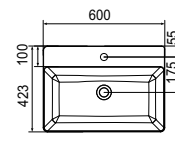
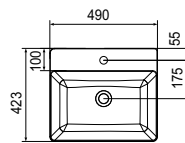
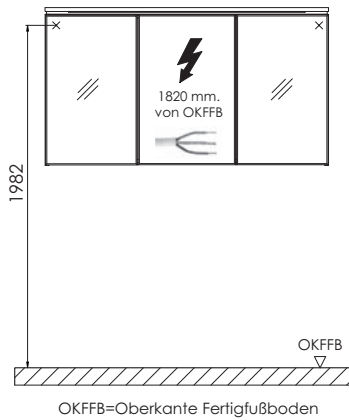

2x WTA S111 1 + 2x WUA 3360 P3 +
2x SDH 4978 01

WTM 4805 + WUA 3360 P3 +
2x SDH 4978 01

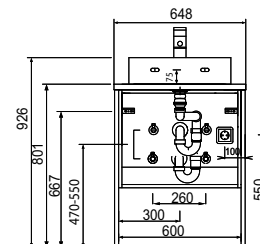
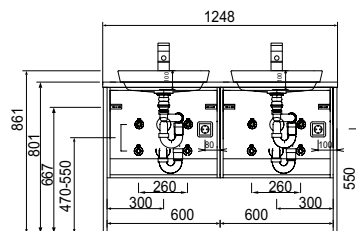
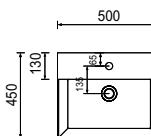
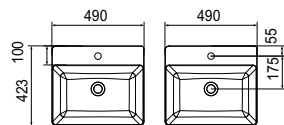

WTM 4806 + WUA 3390 P3 +
2x SDH 4978 01

2x WTM 4805 + 2x WUA 3360 P3 +
2x SDH 4978 01

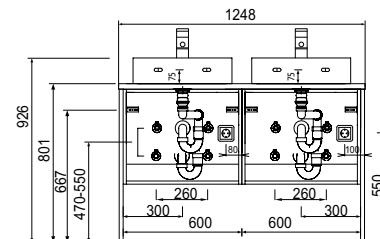
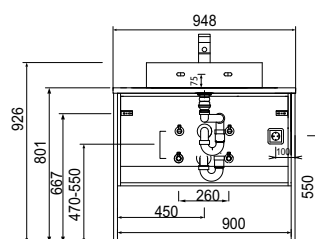
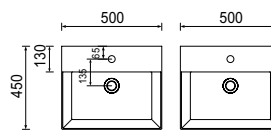
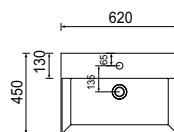

Toleranzen:

Die Maßtoleranzen (+/- 5mm) und Ebenheitstoleranzen (DIN 18202) unterliegen den üblichen materialspezifischen Toleranzen für Baustoffe, anlehnend an die DIN 18202.

Programm 066 - Maßskizzen

WTA S111 1 + WUA 3360 P3

WTA S112 1 + WUA 3390 P3

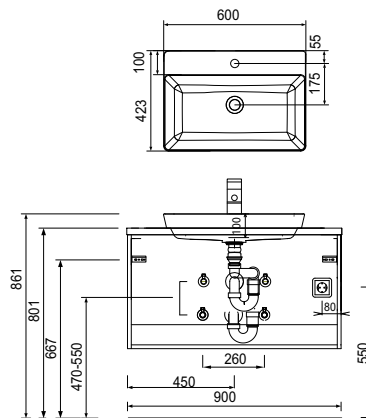
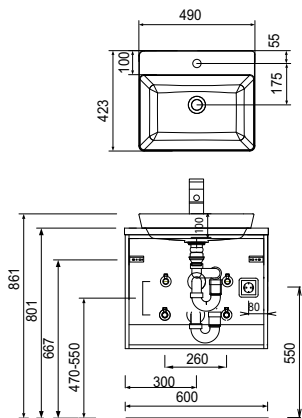

2x WTA S111 1 + 2x WUA 3360 P3

WTM 4805 + WUA 3360 P3

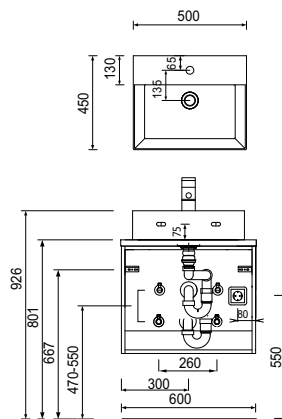
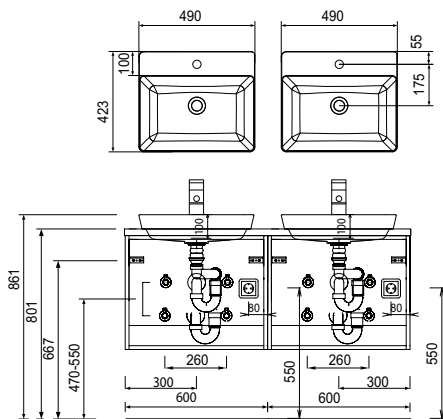

WTM 4806 + WUA 3390 P3

2x WTM 4805 + 2x WUA 3360 P3

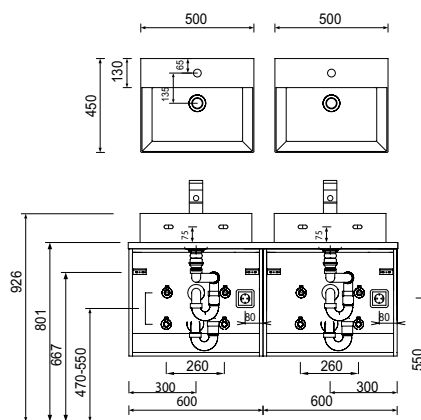
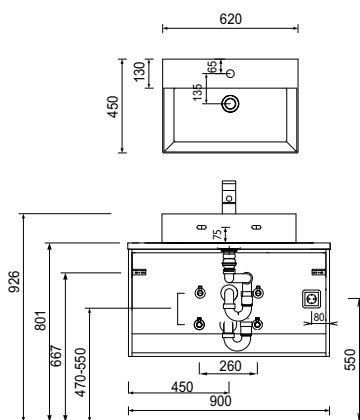

Toleranzen:

Die Maßtoleranzen (+/- 5mm) und Ebenheitstoleranzen (DIN 18202) unterliegen den üblichen materialspezifischen Toleranzen für Baustoffe, anlehnd an die DIN 18202.