

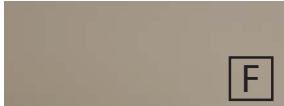

Front colours



No. 764 Stonegrey matt



No. 777 cosmos grey matt

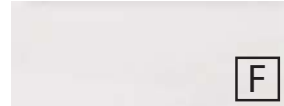

No. 793 noble white matt



No. 891 quarz grey matt



No. 893 titanium grey matt



No. 686 anthracite hgl.



No. 722 polar white hgl.



no. 680 Charleston oak



Nr. 785 natural oak



no. 794 sand oak

F foiled front

Program 033 - dimensional drawings

SWM 109L

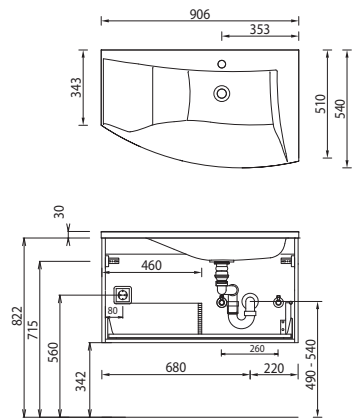

SWM 109R

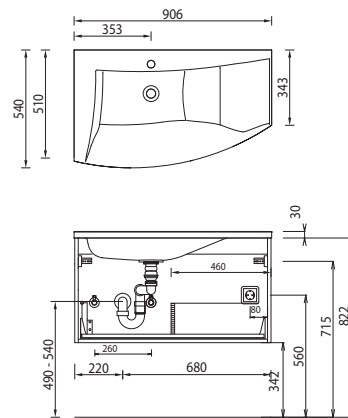

SWM 112L

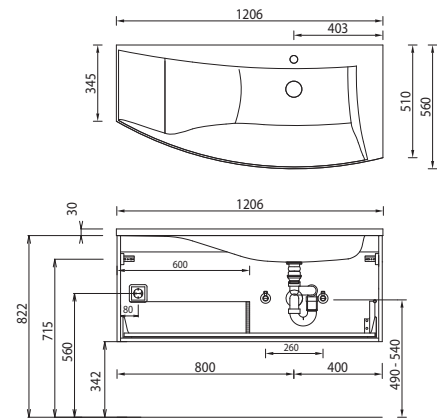

SWM 112R

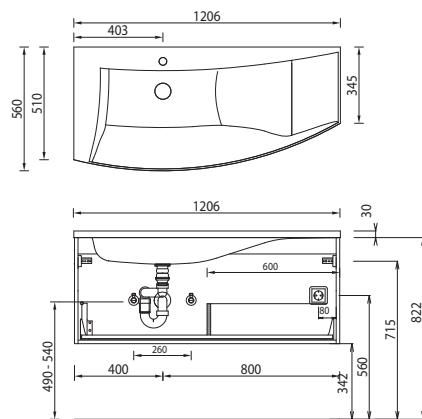

SWM 114L

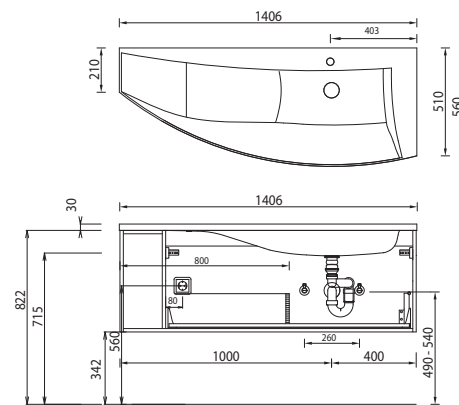

SWM 114R

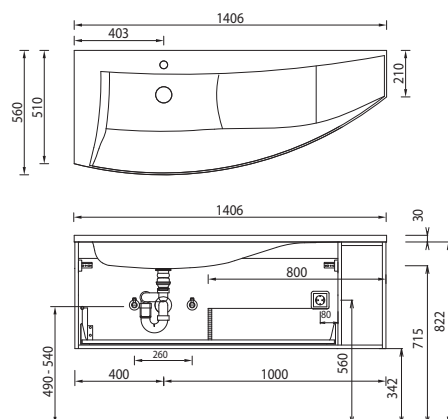

SWG 109L

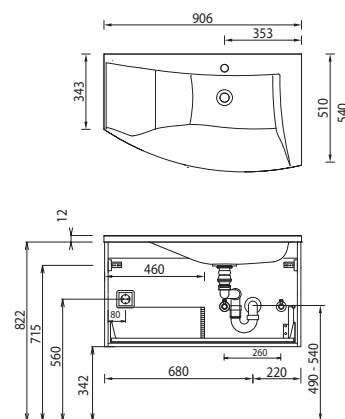

SWG 109R

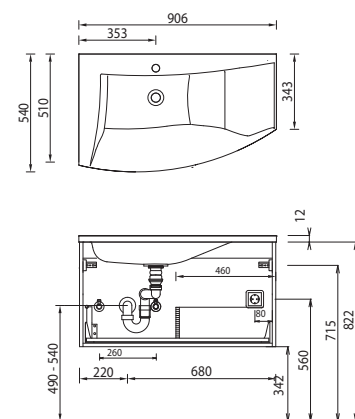

For washing stands with fixing screws, the dimensions for boring must be drawn in on-site after the washing stand has been laid on the floor unit.

Washing stands without anchoring brackets have to be fixed on the wall and on the furniture-side with silicon!

Evermite:

The water temperature must not exceed 55° C / 131° F. Hair tinting lotions have to be removed in a few seconds, so that staining can be avoided.

Modifications:

Technical modifications (+/- 5mm) and flatness modifications (DIN 18202) are subject of the usual material-specific modifications for construction materials, based on DIN 18202.

Program 033 - dimensional drawings

SWG 112L

SWG 112R

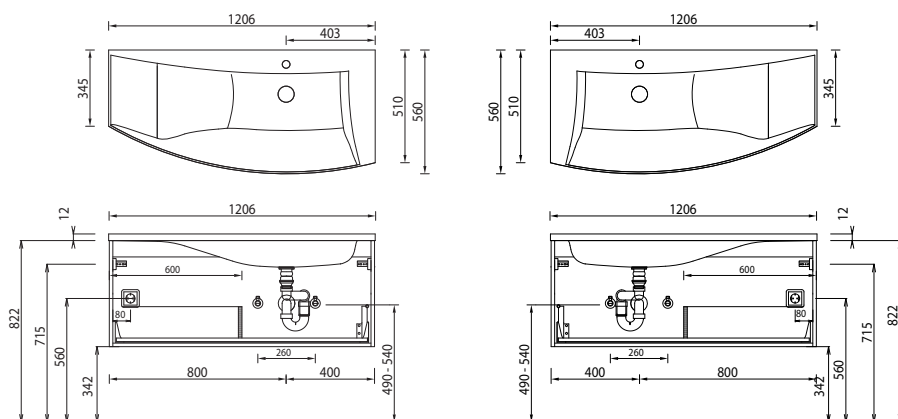

SWG 114L

SWG 114R

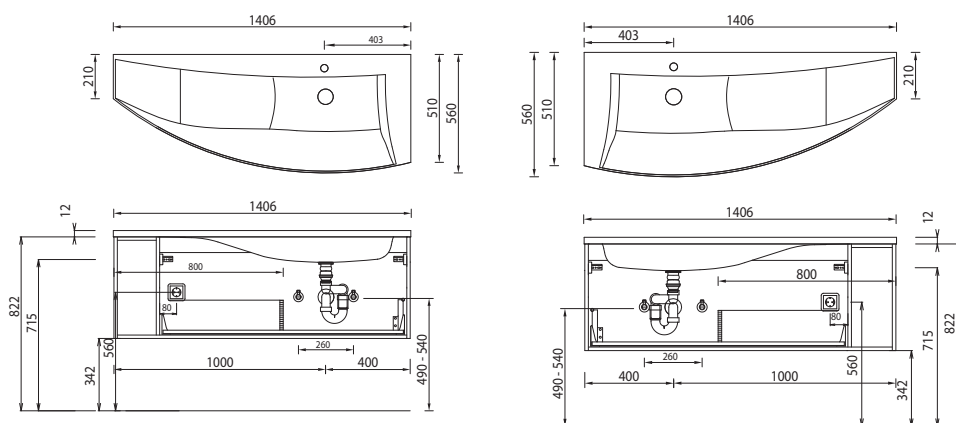

electrical connections for mirror cabinets

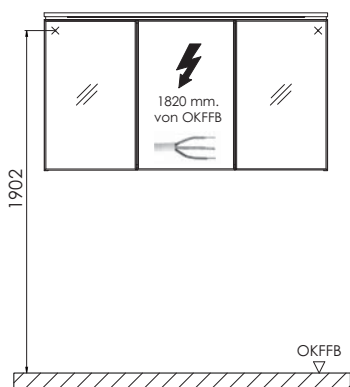

OKFFB=Oberkante Fertigfußboden

For washing stands with fixing screws, the dimensions for boring must be drawn in on-site after the washing stand has been laid on the floor unit.

Washing stands without anchoring brackets have to be fixed on the wall and on the furniture-side with silicon!

Evermite:

The water temperature must not exceed 55° C / 131° F. Hair tinting lotions have to be removed in a few seconds, so that staining can be avoided.

Modifications:

Technical modifications (+/- 5mm) and flatness modifications (DIN 18202) are subject of the usual material-specific modifications for construction materials, based on DIN 18202.