

Program 045 - dimensional drawings

WME 3307 1

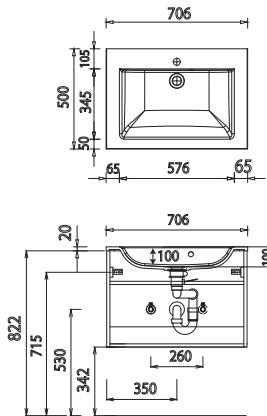

WME 3310 1

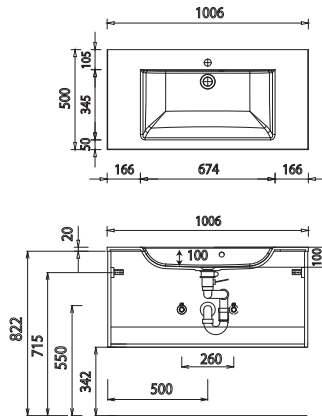

WME 3312 1

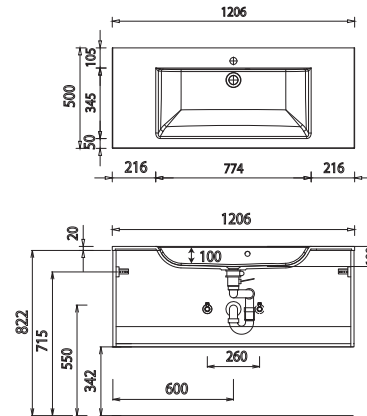

WME 332D 1

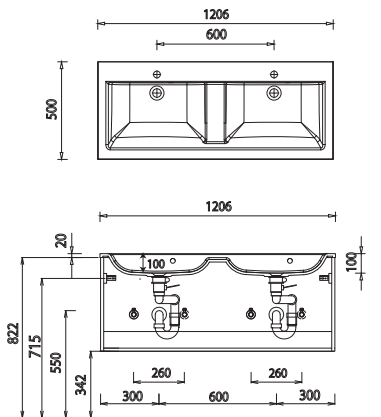

WGE 3307 82

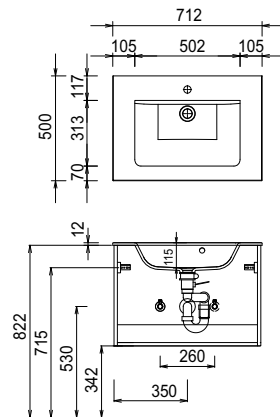

WGE 3310 82

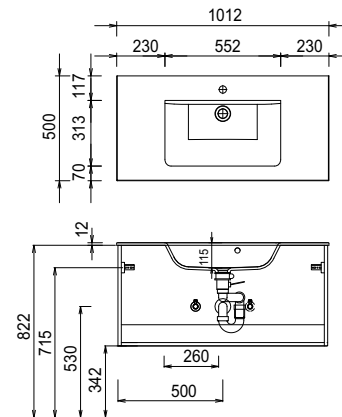

WGE 3312 82

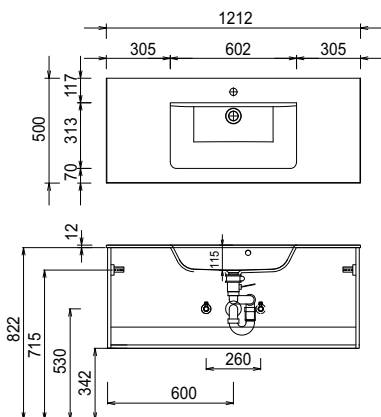

WGE 332D 82

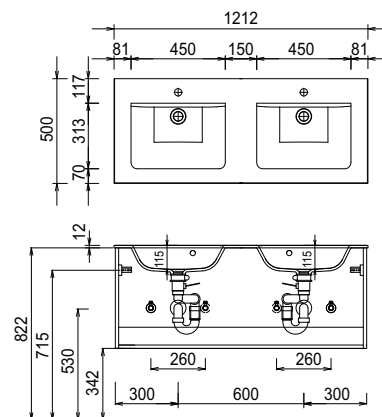

WTM 4407 1

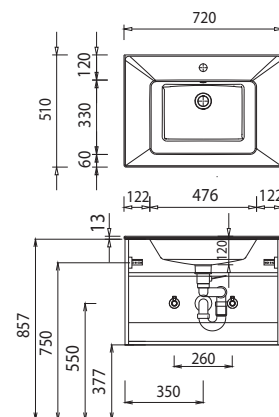

For washing stands with fixing screws, the dimensions for boring must be drawn in on-site after the washing stand has been laid on the floor unit.

Washing stands without anchoring brackets have to be fixed on the wall and on the furniture-side with silicon!

Cast mineral:

The water temperature must not exceed 55° C / 131° F. Hair tinting lotions have to be removed immediately, so that staining can be avoided.

Modifications:

Technical modifications (+/- 5mm) and flatness modifications (DIN 18202) are subject of the usual material-specific modifications for construction materials, based on DIN 18202.

Program 045 - dimensional drawings

WTM 4410 1

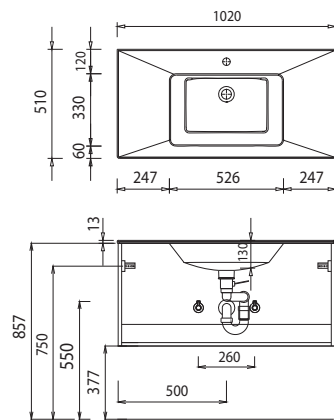

WTM 4412 1

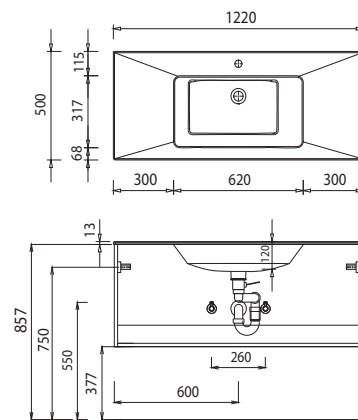

WTM 442D 1

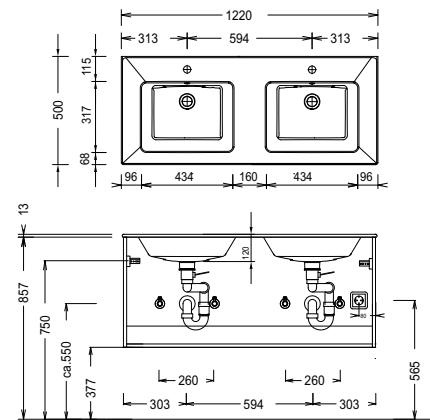

electrical connections for mirror cabinets

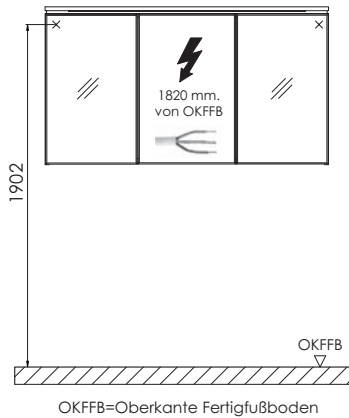

For washing stands with fixing screws, the dimensions for boring must be drawn in on-site after the washing stand has been laid on the floor unit.

Washing stands without anchoring brackets have to be fixed on the wall and on the furniture-side with silicon!

Cast mineral:

The water temperature must not exceed 55° C / 131° F. Hair tinting lotions have to be removed immediately, so that staining can be avoided.

Modifications:

Technical modifications (+/- 5mm) and flatness modifications (DIN 18202) are subject of the usual material-specific modifications for construction materials, based on DIN 18202.