



Front colours

Price group 1



No. 679 concrete imitation



No. 777 cosmos grey matt



No. 775 steel grey dark matt



No. 891 quarz grey matt



No. 893 titanium grey matt



no. 670 Halifax oak



no. 680 Charleston oak



No. 750 cardiff oak



Nr. 785 natural oak



no. 786 truffle oak

Price group 2

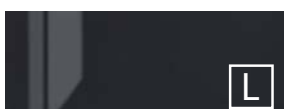

No. 789 carbon lacquer hgl.



No. 788
Grey lacquer hgl.



No. 787
white lacquer hgl.

F foiled front

M Melamine coated front with ABS-edge

L lacquered front

Program 067 - dimensional drawings

WTM 4806 + WUA 3360 33

WTM 4808 + WUA 3380 33

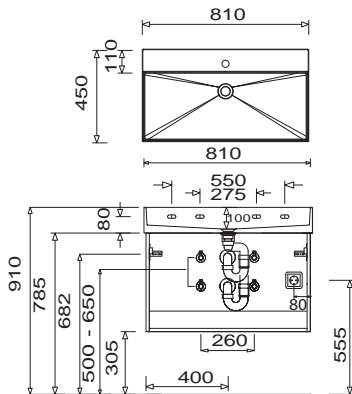
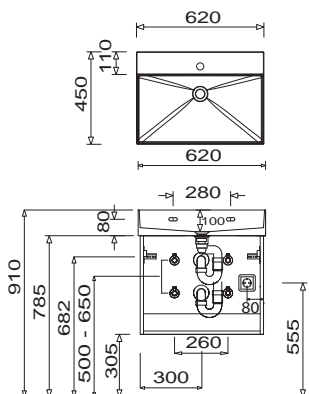

WTM 4810 + WUA 3310 33

WTM 4821 + WUA 3310 33

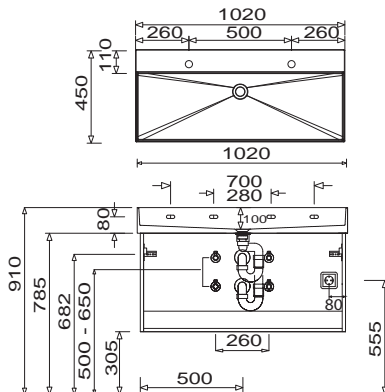
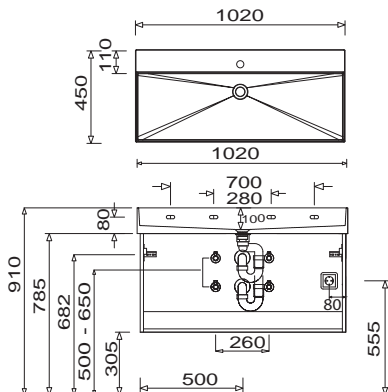

WTM 4812 + WUA 3312 33

WTM 482D + WUA 332D 33

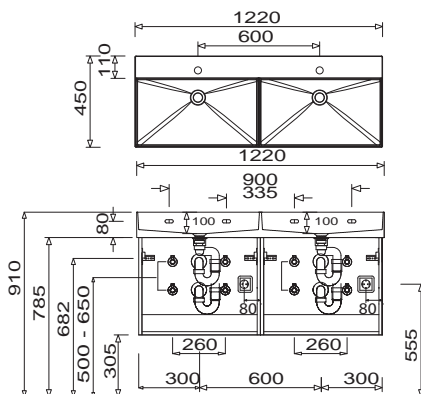
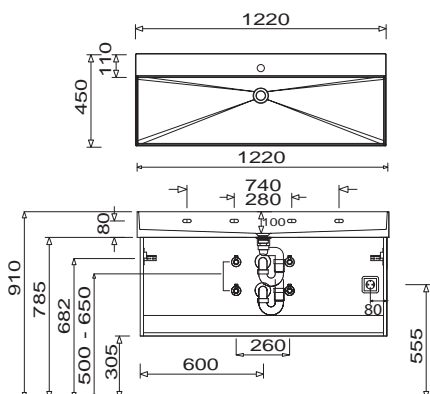

For washing stands with fixing screws, the dimensions for boring must be drawn in on-site after the washing stand has been laid on the floor unit.

Washing stands without anchoring brackets have to be fixed on the wall and on the furniture-side with silicon!

Modifications:

Technical modifications (+/- 5mm) and flatness modifications (DIN 18202) are subject of the usual material-specific modifications for construction materials, based on DIN 18202.

Program 067 - dimensional drawings

WTM 4806 + WUA 4360 2G

WTM 4808 + WUA 4380 2G

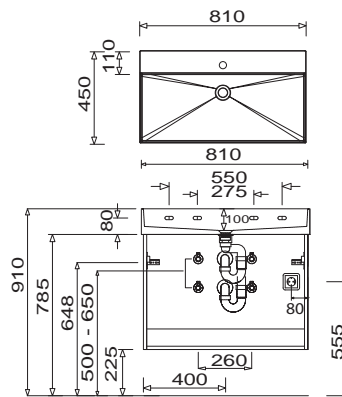
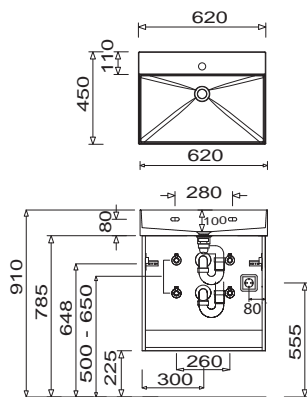

WTM 4810 + WUA 4310 2G

WTM 4821 + WUA 4310 2G

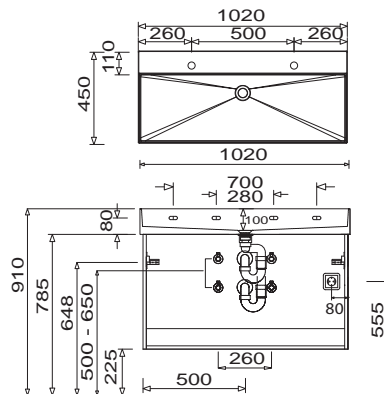
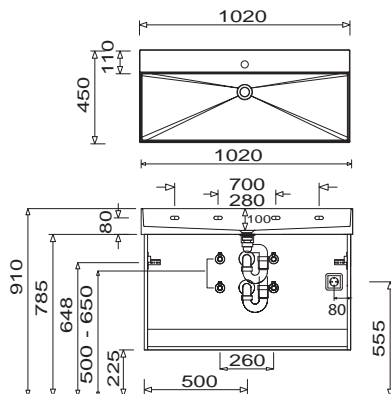

WTM 4812 + WUA 4312 2G

WTM 482D + WUA 4312 2G

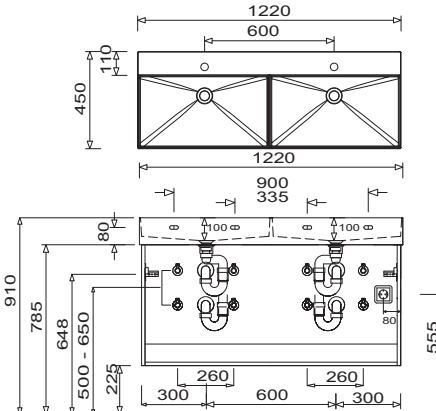
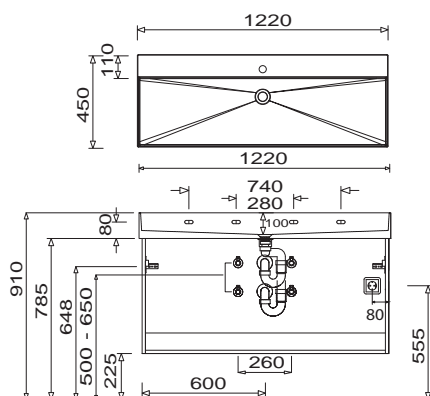

For washing stands with fixing screws, the dimensions for boring must be drawn in on-site after the washing stand has been laid on the floor unit.

Washing stands without anchoring brackets have to be fixed on the wall and on the furniture-side with silicon!

Modifications:

Technical modifications (+/- 5mm) and flatness modifications (DIN 18202) are subject of the usual material-specific modifications for construction materials, based on DIN 18202.

Program 067 - dimensional drawings

WTM 482D + WUA 432D 2G

WTM 5006 + WUA 3360 33

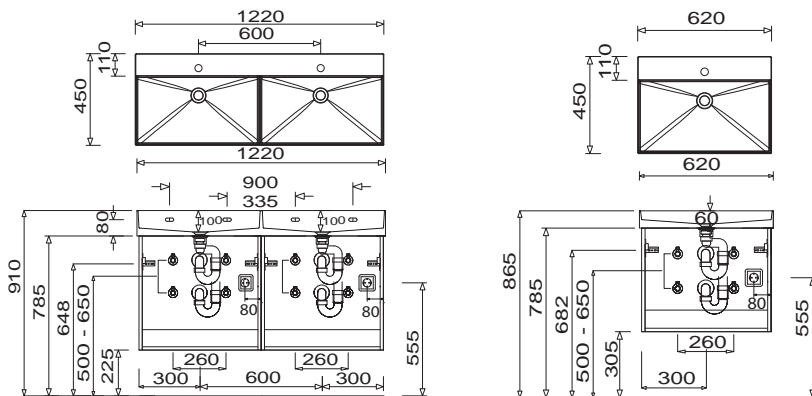

WTM 5008 + WUA 3380 33

WTM 5010 + WUA 3310 33

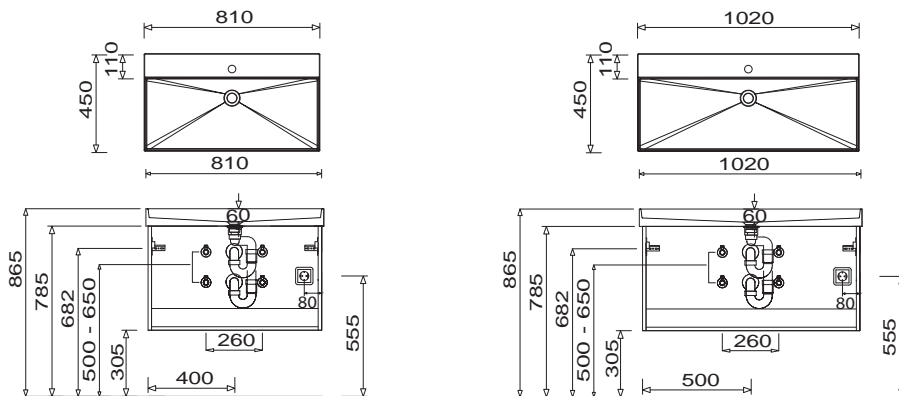

WTM 5021 + WUA 3310 33

WTM 502D + WUA 332D 33

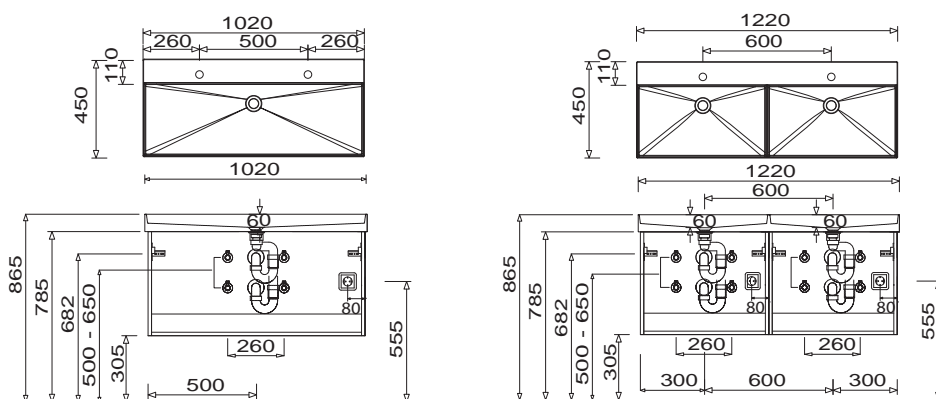

For washing stands with fixing screws, the dimensions for boring must be drawn in on-site after the washing stand has been laid on the floor unit.

Washing stands without anchoring brackets have to be fixed on the wall and on the furniture-side with silicon!

Modifications:

Technical modifications (+/- 5mm) and flatness modifications (DIN 18202) are subject of the usual material-specific modifications for construction materials, based on DIN 18202.

Program 067 - dimensional drawings

WTM 5006 + WUA 4360 2G

WTM 5008 + WUA 4380 2G

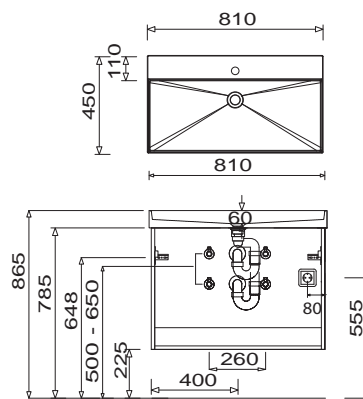
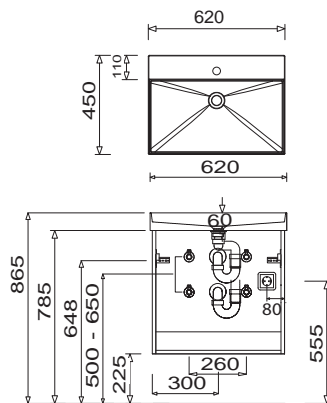

WTM 5010 + WUA 4310 2G

WTM 5021 + WUA 4310 2G

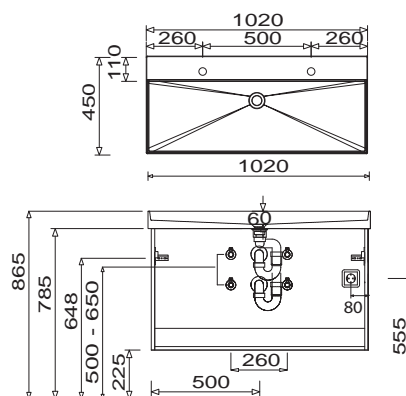
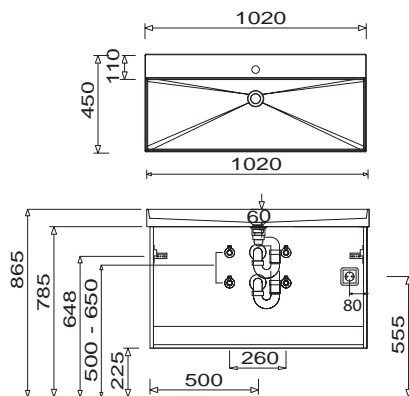

WTM 502D + WUA 4312 2G

WTM 502D + WUA 432D 2G

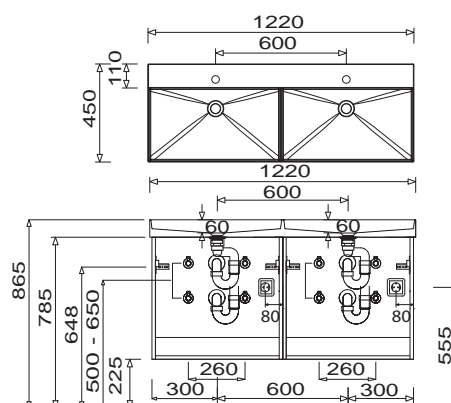
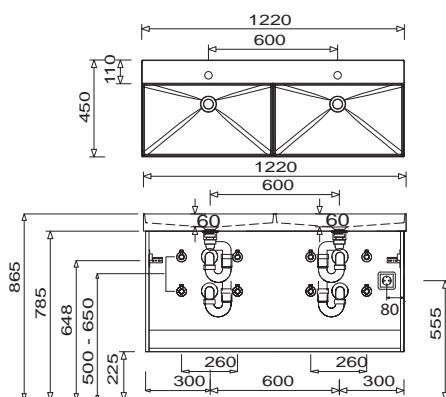

For washing stands with fixing screws, the dimensions for boring must be drawn in on-site after the washing stand has been laid on the floor unit.

Washing stands without anchoring brackets have to be fixed on the wall and on the furniture-side with silicon!

Modifications:

Technical modifications (+/- 5mm) and flatness modifications (DIN 18202) are subject of the usual material-specific modifications for construction materials, based on DIN 18202.

Program 067 - dimensional drawings

electrical connections for mirror cabinets

S2A 5360/80/90/10/12/14 E1

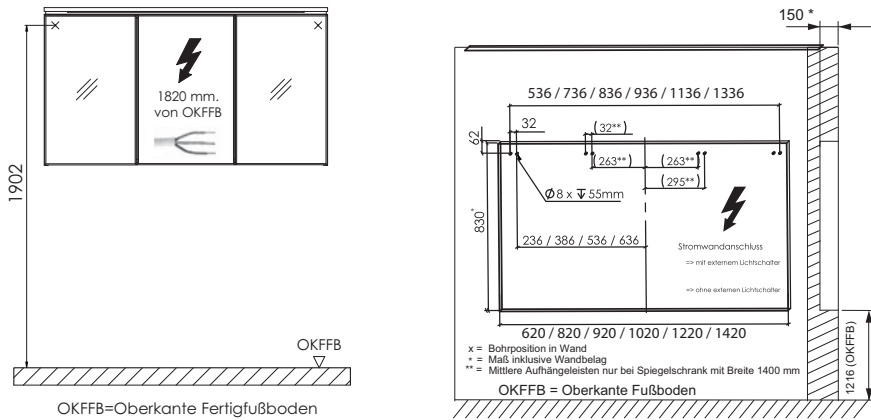

For washing stands with fixing screws, the dimensions for boring must be drawn in on-site after the washing stand has been laid on the floor unit.

Washing stands without anchoring brackets have to be fixed on the wall and on the furniture-side with silicon!

Modifications:

Technical modifications (+/- 5mm) and flatness modifications (DIN 18202) are subject of the usual material-specific modifications for construction materials, based on DIN 18202.